

CONTINUOUS BAND SEALING OF MEDIUM TO HEAVY DUTY APPLICATIONS FOR DIFFICULT TO SEAL POUCH / BAG MATERIALS

MODEL VBS-DH-10

- USDA Approved rotary sealing system.
- Unit is designed with two 5" heating sections (10" total) and two 5" cooling sections (10" total) for greater flexibility in product sealing of difficult materials with temperatures up to 500 degrees +/- 2 degrees Fahrenheit.
- Extra sealing capacity allows speeds up to 45' per minute with constant secure seals of 1/8", 1/4" or 3/8" wide without bag top trimmer.
- Designed to seal Kraft/PE, Nylon, Polyethylene, Polypropylene, Laminates, Tyvek / Polymylar and Foil.
- Seals are achieved through the use of special heavy duty wear-resistant laminated Teflon bands.



- Dual temperature controls maintain consistent heat and assures quality hermetic seals. Heat is generated from front and rear heaters or one set only as required using a simple on/off switch. Individual heating assemblies can be regulated because of dual controls.
- Mounted on a heavy duty floor model adjustable stand with crank handle and can be operated in the vertical or horizontal position. Unit can be positioned over existing lower carry conveyor.
- Chassis sealing assembly construction of stainless steel shafting throughout and anodized aluminum assuring longevity of use. Chrome plated sealing assemblies reduces wear.
- Adjustable height sealing assembly with crank handle.
- No compressed air required, 110V, 1 Phase, 60 Cycle.

APPLICATIONS

Medical
Pharmaceutical
Chemicals
Food
Candy

Textiles
Poultry
Meat
Bakery
Toys

Seafood
Crafts
Disposables
Hardware
Garden

Electronics
Pet
Decorative
Automotive
Mailroom

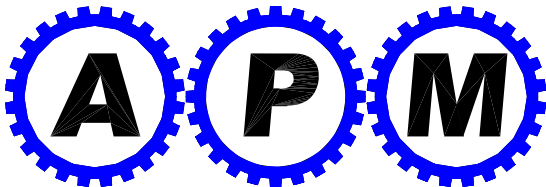

OVER 50 YEARS OF SUCCESSFUL PACKAGING EXPERIENCE

ALL PACKAGING MACHINERY, CORP.

90 13th Avenue, Ronkonkoma, NY 11779

(631) 588-7310 Fax (631) 467-4690

Call Toll Free 1-800-637-8808

www.allpackagingmachinery.com

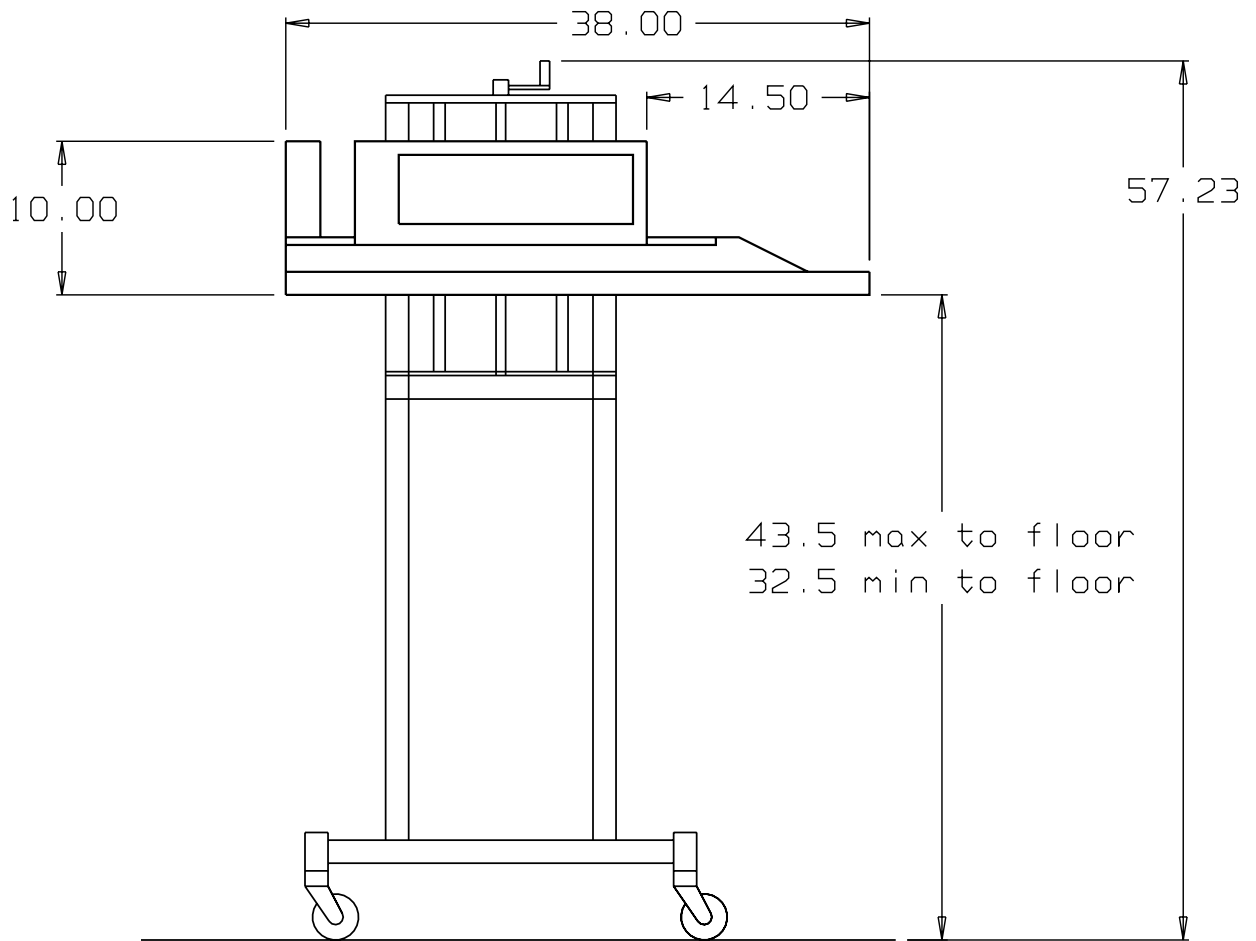
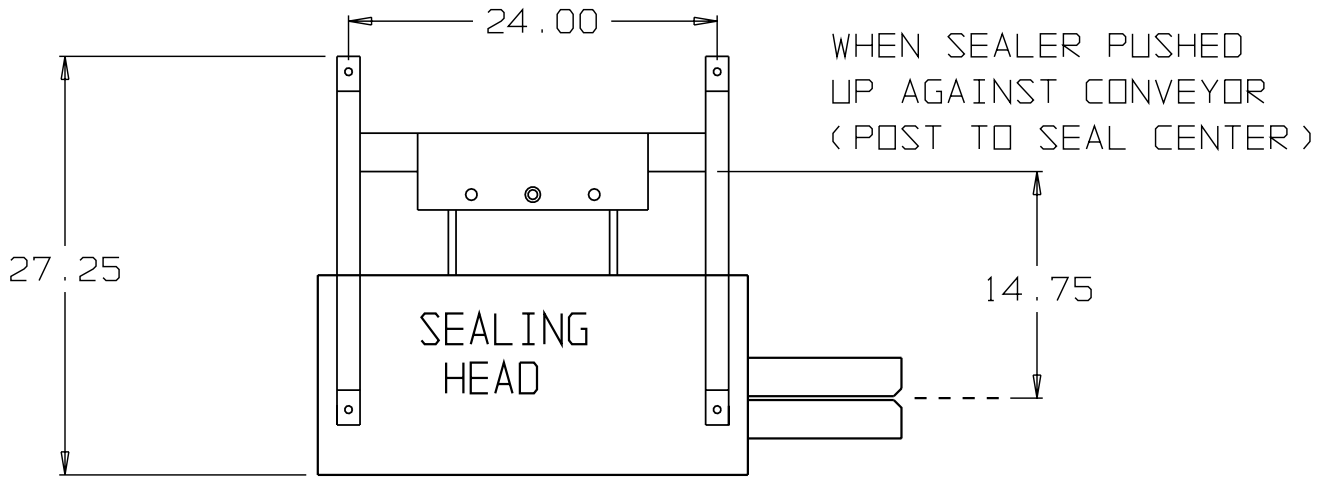

ELECTRIC: 115 VAC 50/60 HZ
1 PHASE 600 WATTS

ALL DIMENSIONS IN INCHES

<h1 style="margin: 0;">APM</h1>		ALL PACKAGING MACHINERY CORP. Ronkonkoma, N.Y. 11779 (631) 588 7310 Fax: (631) 467 4690	
		CADKEY FILE: VCBS-VBS FLOOR	
DRAWN BY: DAN WOOD		MATERIAL:	
APP'D. BY:		SIZE: A	
DATE: 1/6/03	REV: N/A	DRAWING NO. VBS-3/8-DH-10	REV.
SCALE: NA	UNITS: INCHES		